

VARIPROP

Manual for the Feathering Propeller

DF-80 and DF-107

2-, 3- and 4 blade model

Installation on the shaft	page 2
Installation on the Saildrive	page 3
Operation	page 4
Pitch adjustment LH (left-hand rotation propeller)	page 5
Pitch adjustment RH (right-hand rotation propeller)	page 6
Defining and checking adjustments	page 7
Removing from the shaft (after one or two seasons)	page 8
Removing from the shaft (after the 3rd season)	page 9
Servicing	page 10
Torque settings prop-nut	page 11

INSTALLATION on the shaft

The VARIPROP is delivered assembled, greased and ready for installation.

Before fitting the VARIPROP onto the shaft, check key and keyway in the propeller hub. Take care that the key is the proper dimension and that the hub slides completely onto the shaft (see below). Remove the zinc anode (2) and the nut (4). Fit the propeller onto the shaft strongly. Tighten the nut (4) with LOCTITE low (pink) onto the shaft (torque-setting see page 11) and secure it with the lock pins (3). Fit the anode (2).

Make sure that the propeller is always protected from electrolytic corrosion by changing the anode (2) latest every year! May not be necessary in freshwater.

After the VARIPROP has been fitted properly check that the blades rotate freely from the forward stop to the reverse stop. The shock absorber function can be felt ! See servicing page 10.

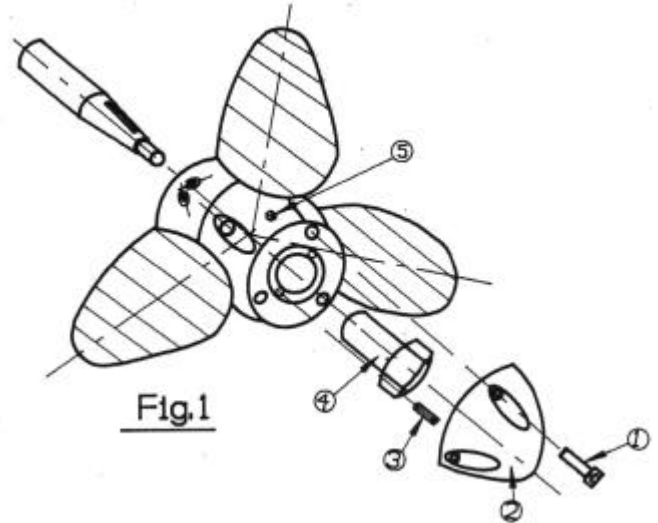

MOUNTING: First slide the prop on the shaft without key. Mark the shaft with a grease-pen at the prop end. After tightening the shaft nut very strongly (torque-setting see page 11) the mark must disappear. If not, the key is binding and the top or the sides of the key must be filed down. Light must be shining through on the top of the key when looking into the hub from astern. You may have to move your eye vertically to see it.

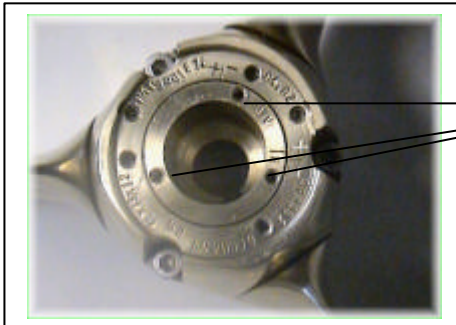

Only two of the three lock-pin holes can be used, depending on the final position of the shaft-nut flange.

Carefully align the lock-pins (3) straight. They must go in easily. If not, try first to tighten the propnut a little further until they do. If impossible, back off the nut a little. The lock-pins should be hand tightened only. If overtightened they may strip.

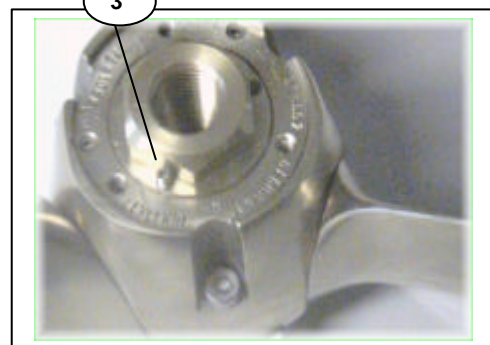

ATTACHING THE ZINC-CONE:

First, insert all three zinc-cone screws (1) loosely, then tighten securely in succession. Use LOCTITE low (pink) and observe the little washers. They prevent the grease from squeezing out of the hub during operation. Be sure to clean the screws and screw-holes from any grease before applying the loctite.

ENGINE DRY TEST:

Please consider that the dry test of the engine **MUST NOT** be done while the VARIPROP is fitted onto the shaft ! The VARIPROP needs water pressure on the blades, otherwise the prop could be damaged !!

INSTALLATION on the SAILDRIVE

The VARIPROP is delivered assembled, greased and ready for installation.

Before mounting the VARIPROP properly onto the saildrive spline, please check if the propeller hub gears mate precisely with the saildrive spline grooves. Tolerances are very tight to avoid on-axis movement. Some careful "wiggling" may be required to find the exact position where the hub slides onto the spline. After removal of the zinc cone (4) and the propeller nut (1) the propeller hub will slide completely onto the spline. Tighten nut (1) strongly (60Nm / 45ft/lb; Yanmar SD 40/50 100Nm / 75ft/lb) and use loctite low (pink) . **Observe the recommended torque settings of the saildrive manufacturer.** After installation, check that there is only a little end clearance for the prop on the saildrive shaft. If it is too high, fit one or more of the different spacer disc between the forward end of the prop and the saildrive to reduce it. The spacer discs are delivered with the prop. Secure the propeller nut (1) with the hexagonal socket cap screw (2 (15Nm / 10ft/lb) and two lock pins (3). Hand tighten only, and then mount the zinc cone (see below). Make sure that the propeller is always protected from electrolytic corrosion by changing the zinc anode (2) latest every year, less often in fresh water. After the VARIPROP has been fitted properly check that the blades rotate freely from the forward stop to the reverse stop. The shock absorber function can be felt ! See servicing page 10.

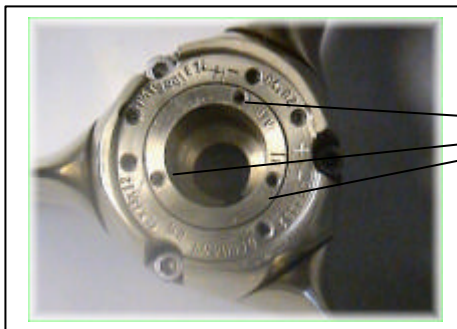
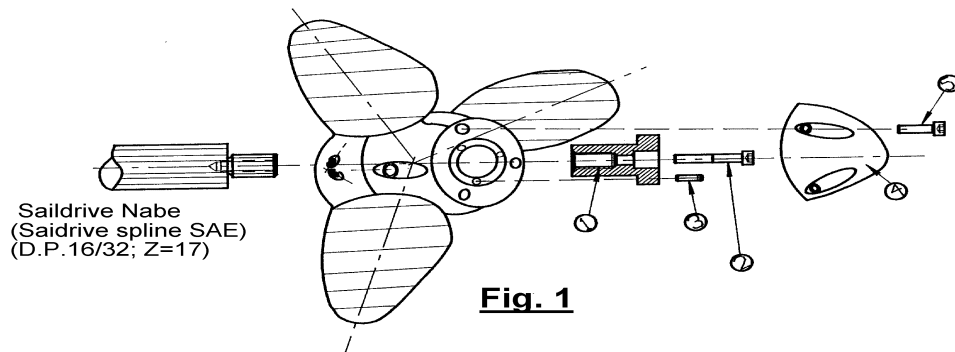

Only two of the three lock-pin holes can be used, depending on the final position of the shaft-nut flange.

Carefully align the lock-pins (3) straight. They must go in easily. If not, try first to tighten the propnut a little further until they do. If impossible, back off the nut a little. The lock-pins should be hand tightened only. If overtightened they may strip.

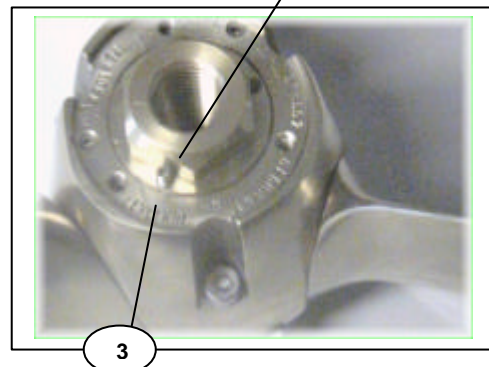

ATTACHING THE ZINC-CONE:

First, insert all three zinc-cone screws (1) loosely, then tighten securely in succession. Use LOCTITE low (pink) and observe the little washers. They prevent the grease from squeezing out of the hub during operations. Be sure to clean the screws and screw-holes from any grease before applying the loctite.

OPERATION

The Variprop feathers automatically when the shaft rotation is stopped. After engine start-up and shifting into gear the blades will engage in either forward or reverse.

THE BEST WAY TO FEATHER THE PROPELLER IN THE SAILPOSITION IS:

VARIPROP sailposition with mechanical gear-box:

- + Power at 3 to 4 knots in forward.
- + **Stop the engine** and engage the transmission in reverse to stop the freewheeling of the shaft.

VARIPROP sailposition with hydraulic transmission:

- + Power at 3 to 4 knots in forward.
- + Stop the engine while still engaged in forward. The remaining oil pressure of the transmission will stop spinning the shaft to feather the blades in the sailposition.

If the propeller is not feathered in the sailposition the shaft will freewheel like with a fixed propeller.

In that case start the engine again and repeat the steps above.

Once the prop is feathered , it is better to shift the transmission to neutral.

DO NOT stop the engine while it turns in reverse. In this case the blades will stay in the reverse position and will not feather. You can actually use this feature to drive a shaft generator.

TROUBLE SHOOTING: If the propeller does not work in forward or reverse go systematically through the points below:

- + Check low idle of the engine. It should be 800 to 900 rpm in idle.
- + Check shifting movement of the transmission lever. Make sure that the shifting travel is not too short. The amount of lever travel, as measured at the pivot point of the actuating lever, between the neutral position and end positions for forward and reverse can be found in the owners manual of your transmission. A larger amount of lever travel is in no way detrimental.
- + Check the clutch discs of the transmission. They could be worn out.

WARNING: It is important to follow the instructions below carefully so as to avoid excessive load and shock to the gears, shortening their life.

- + When going from ahead to astern or the opposite, it is necessary to idle down and shift at low rpm's (max.1200rpm) between gears to allow smooth reversing of rotation without binding. This will substantially lengthen the service life of your propeller gears.
- + When going from ahead to astern or the opposite, you can hear the turning-noise of the feathering blades. This is normal and not a problem or a defect of your VARIPROP.
- + The propeller body must always be completely filled with a high viscosity grease. We recommend synthetic grease typ TW.2 GEL or mineral multi-purpose grease EP/SAL 8 (see servicing page 10)
- + The propeller must be protected from electrolytic corrosion by fitting the usual zinc anodes on the shaft plus the prop anode.
- + If you want to protect your VARIPROP with Antifouling, use only Antifouling which needs a primer first. Otherwise chemical interaction and decomposition could occur. Our recommendation is *Velox TF plus* including a primer, available from your VARIPROP distributor.
- + **Never dismantle the VARIPROP yourselves !!**
Disassembly and reassembly require special tools and technical know-how only available at the factory or their approved service centres.

PITCH ADJUSTMENT „LH“

GERNAL: The pitch adjustment is very simple on the VARIPROP, and can be done in or out of the water in a matter of few minutes, if there is enough space between propeller hub and strut to fit an allen key into the set screws (1) & (3) at Fig.2 . If not, the propeller must first be pulled. (see removing from the shaft)

Propeller in the drawing below (Fig.2) is for a **left hand** rotation VARIPROP **LH**.

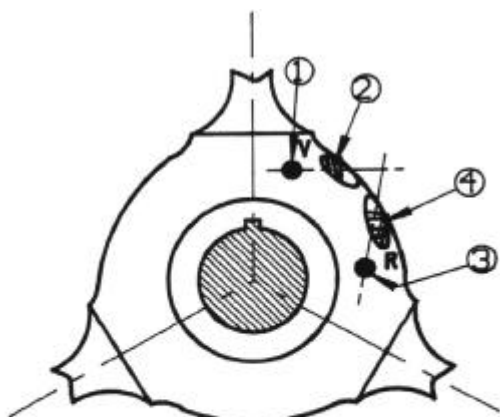
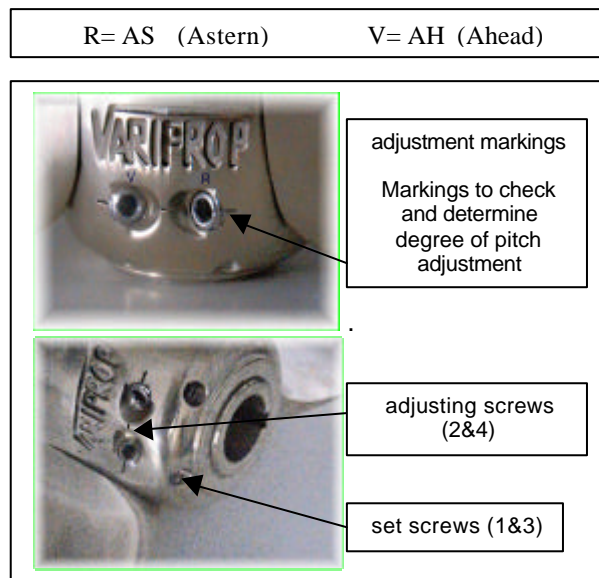

Fig.2



The following description refers to the view towards astern for a **left hand VARIPROP**.

A. Adjusting the forward pitch:

1. Remove the set screw (1/ 4mm allen key).
Under water: only 3 turns loosen.
2. Turn the adjusting screw (2) which is marked as **“AH” or “V”** with the 5mm Allen-key as follows:

2a. Increasing of pitch approx. 3“ max.:

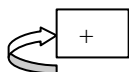

- Turn the adjusting screw (2) clockwise.
(see “NOTE” and page 7)
- Secure set screw (1) with LOCTITE low (pink)
Lock set screw strongly.

2b. Reducing of pitch approx. 2“ max.:

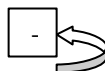

- Turn the adjusting screw (2) anti-clockwise.
(see “NOTE” and page 7).
- Secure set screw (1) with LOCTITE low (pink)
- Lock set screw strongly.

B. Adjusting the reverse pitch:

1. Remove the set screw (3/ 4mm allen key).
Under water: only 3 turns loosen.
2. Turn the adjusting screw (4) which is marked as **“AS” or “R”** with the 5mm Allen-key as follows:

2a. Increasing of pitch approx. 2“ max.:

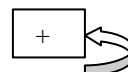

- Turn the adjusting screw (4) anti-clockwise.
(see “NOTE” and page 7)
- Secure set screw (3) with LOCTITE low (pink)
Lock set screw strongly.

2b. Reducing of pitch approx. 3“ max.:

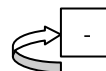

- Turn the adjusting screw (4) clockwise.
(see “NOTE” and page 7).
- Secure set screw (3) with LOCTITE low (pink).
- Lock set screw strongly.

NOTE: It is quite possible to set the pitch continuously variable and independently for forward and reverse. Turning of the adjusting screws (2) & (4) by half a revolution (180°) changes the pitch approx. 1“. This will change the engine revolution by approx.200.

PITCH ADJUSTMENT „RH“

GERNAL: The pitch adjustment is very simple on the VARIPROP, and can be done in or out of the water in a matter of few minutes, if there is enough space between propeller hub and strut to fit an Allen key into the set screws (1) & (3) at Fig.3a. If not, the propeller must first be pulled. (see removing from the shaft)

Propeller in the drawing below (Fig.3a) is for a **right hand rotation RH.**

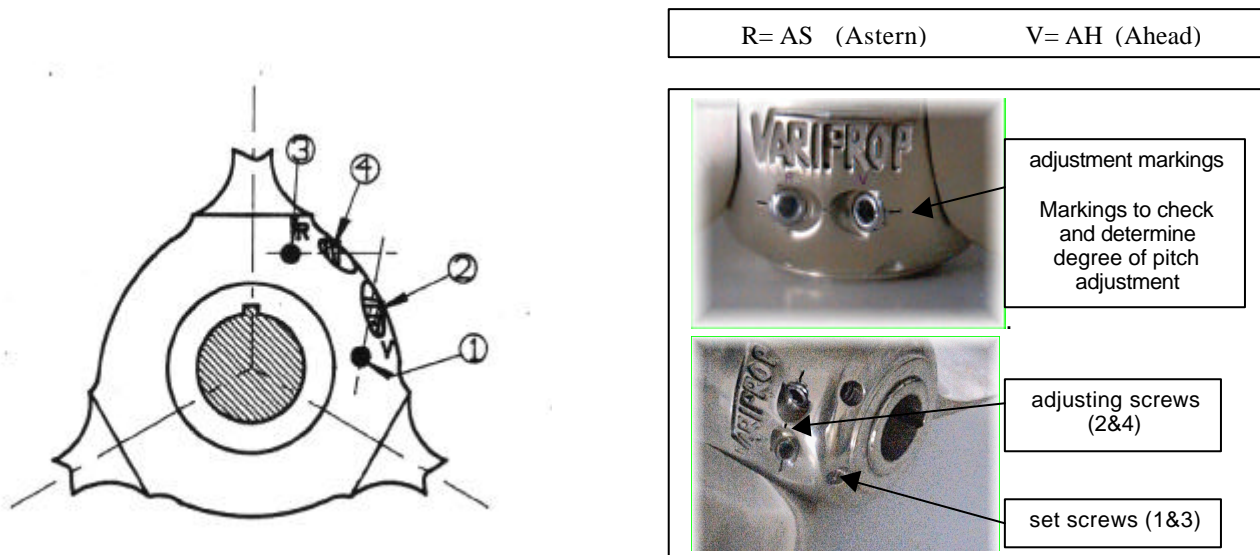

Fig.3a

The following description refers to the view towards astern for a **right hand VARIPROP.**

A. Adjusting the forward pitch :

1. Remove the set screw (1/ 4mm allen key).
Under water: only 3 turns loosen.
2. Turn the adjusting screw (2) which is marked as **“AH” or “V”** with the 5mm Allen-key as follows:

2a. Increasing of pitch approx. 3“ max.:

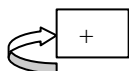

- Turn the adjusting screw (2) clockwise.
(see “NOTE” and page 7)
- Secure set screw (1) with LOCTITE low (pink).
- Lock set screw strongly.

2b. Reducing of pitch approx. 2“ max.:



- Turn the adjusting screw (2) anti-clockwise.
(see “NOTE” and page 7).
- Secure set screw (1) with LOCTITE low (pink).
- Lock set screw strongly.

B. Adjusting the reverse pitch :

1. Remove the set screw (3/ 4mm allen key).
Under water: only 3 turns loosen.
2. Turn the adjusting screw (4) which is marked as **“AS” or “R”** with the 5mm Allen-key as follows:

2a. Increasing of pitch approx. 2“ max.:

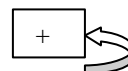

- Turn the adjusting screw (4) anti-clockwise.
(see “NOTE” note and page 7)
- Secure set screw (3) with LOCTITE low (pink).
- Lock set screw strongly.

2b. Reducing of pitch approx. 3“ max.:

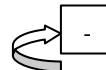

- Turn the adjusting screw (4) clockwise.
(see “NOTE” and page 7).
- Secure set screw (3) with LOCTITE low (pink).
- Lock set screw strongly.

NOTE: It is quite possible to set the pitch continuously variable and independently for forward and reverse. The turning of the adjusting screws (2) & (4) by half a revolution (180°) changes the pitch approx. 1“. This will change the engine revolution by approx. 200.

Defining and checking pitch adjustments

It is quite possible to set the pitch continuously variable and independently for forward and reverse. The turning of the adjusting screws (2) & (4) in Figure 2 & 3a (see pages 5&6) by half a revolution changes the pitch approx. 1". That means a quarter turn (90°) changes the pitch by ½" and a one full turn by 2" etc.. For a check of pitch adjustments there are markings on the hub face under the zinc anode. To return to original factory pitch settings, line up "AH" or "V" resp. "AS" or "R" markings on the hub face.

Example:

check adjustments ahead

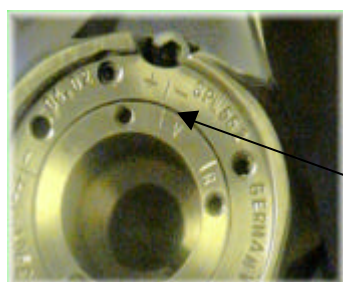

markings
line up

original factory pitch setting
ahead

inner marking has moved

plus

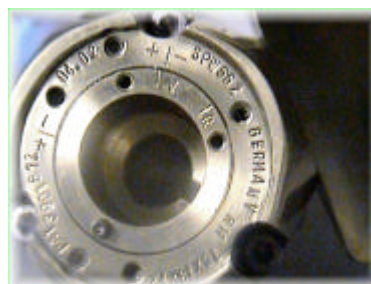

pitch has been increased ahead

check adjustments astern



markings
lined up

original factory pitch setting
astern

inner marking has moved

minus



pitch has been decreased astern

Note :

- If the engine does not reach the desired RPM reduce the pitch.
- If the engine exceeds the desired RPM increase the pitch.
- 1" of pitch reduction / increase results in approx. 200 engine revolutions increase / reduction.

VARIPROP REMOVAL

VARIPROP removal after 1 or 2 seasons.

- 1.) In order to remove the Variprop you must first remove the zinc anode (2).
- 2.) Remove both lock pins (3) and the prop nut (4)

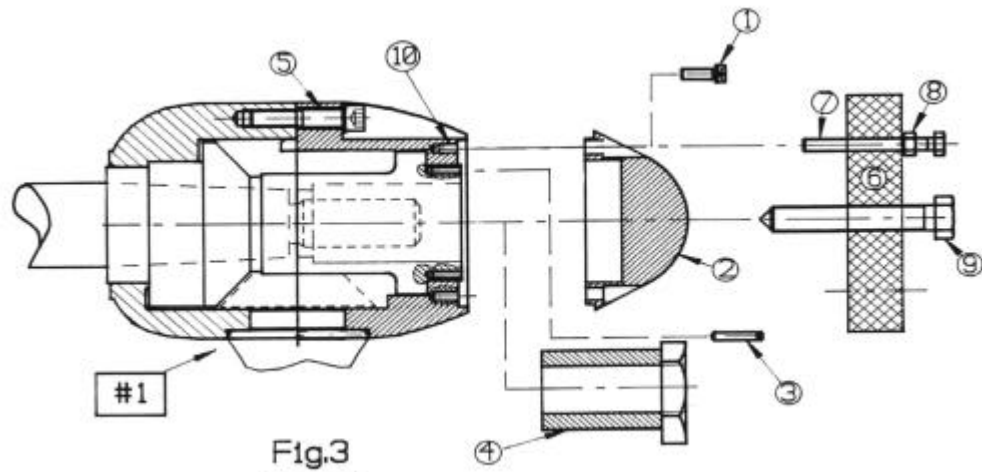

- 3.) Fit the short hexagonal head screws (7) into the inner bolt circle diameter of the puller (6). Fit the SPW puller (6) onto the aft of the rear boss and screw the short hexagonal head screws (7) completely into the zinc screw holes (10). Take care that plate (6) will fit snugly and evenly to the aft boss.

CAUTION: DO NOT OPEN THE HEXAGON SOCKET SCREWS (5) !

It would dismantle the two separate halves of the Variprop hub !!!

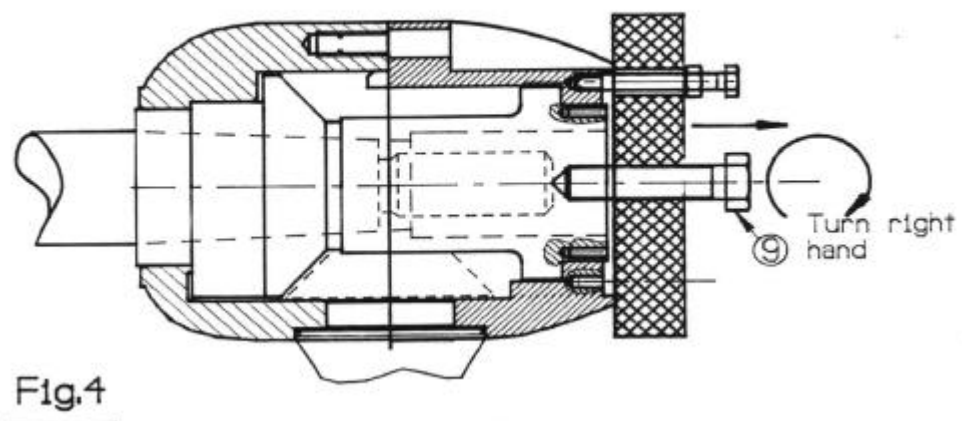

- 4.) Now turn the hexagonal head bolt (9) against the end of shaft until the Variprop comes off the taper. Do not use excessive force to turn bolt (9). If prop does not come off, proceed to page 9 – removal after the 3rd season. Never use a hammer to remove the prop from the taper !!!

- necessary tools for removal see servicing page 10.

VARIPROP REMOVAL

VARIPROP removal after 3 years or more.

- 1.) In order to remove the Variprop you must first remove the zinc anode (2).
- 2.) Remove both lock pins (3) and the prop nut (4)

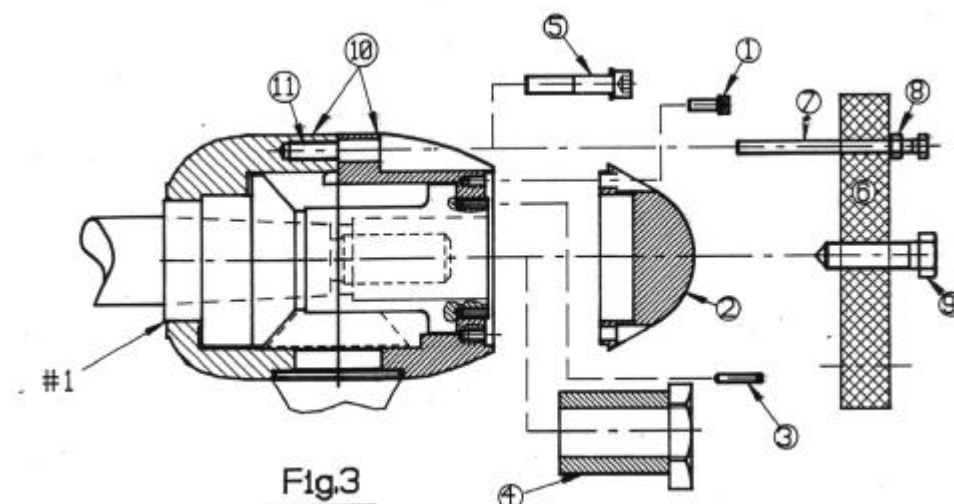

- 3.) Then remove at first only two hexagonal socket screws (5). **DO NOT OPEN ALL !**
- 4.) Fit two of the long hexagonal head screws (7) into the outer bolt circle diameter of the puller (6). Now fit the SPW puller (6) onto the aft of the rear boss and screw the long hexagonal head screws (7) completely into the screw holes (11) of the front boss half (10). Tighten the nut (8) on the head screws (7) until the plate (6) is fitted snugly and evenly to the aft boss.

CAUTION: Do not dismantle the two separate halves of the Variprop hub !!!

In this mode remove the last hexagonal socket screw (5) as well and fit the third long hexagonal head screw. Take care that plate (6) will fit snugly and evenly to the aft boss.

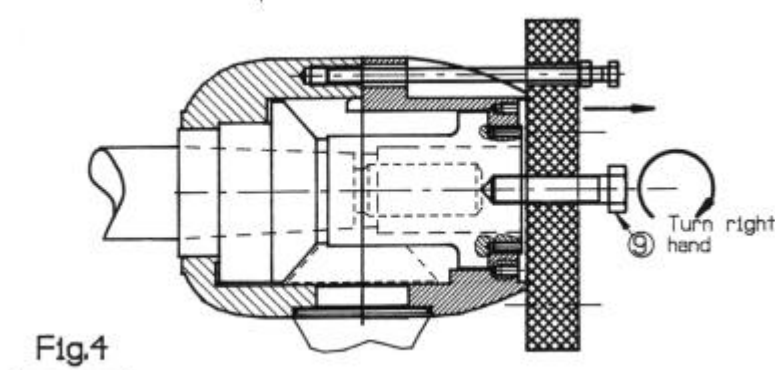

- 5.) Now turn the hexagon head bolt (9) against the end of shaft until the Variprop comes off the taper. Never use a hammer to remove the prop from the taper !!!
- 6.) At the end remove the puller (6) carefully and secure the boss halves (10) with the socket screws (5). Tighten strongly with LOCTITE blue (medium). Take care that the hub halves do not come apart when removing the hexagonal head screws (7).

- necessary tools for removal see servicing page 10.

SERVICING

The VARIPROP needs to be greased a minimum of once a year. The VARIPROP body should always be completely filled with a high viscosity **grease** of a hydrophobic nature. Remove the cap screw (5) and screw in the lubricating nipple which is supplied with the tools. Further remove the zinc anode! With each pump of the grease gun rotate the propeller from forward stop to reverse stop to allow the grease to work through the propeller. Stop to pump when enough grease comes out of the anode drill holes on top of the prop (Fig.1A).

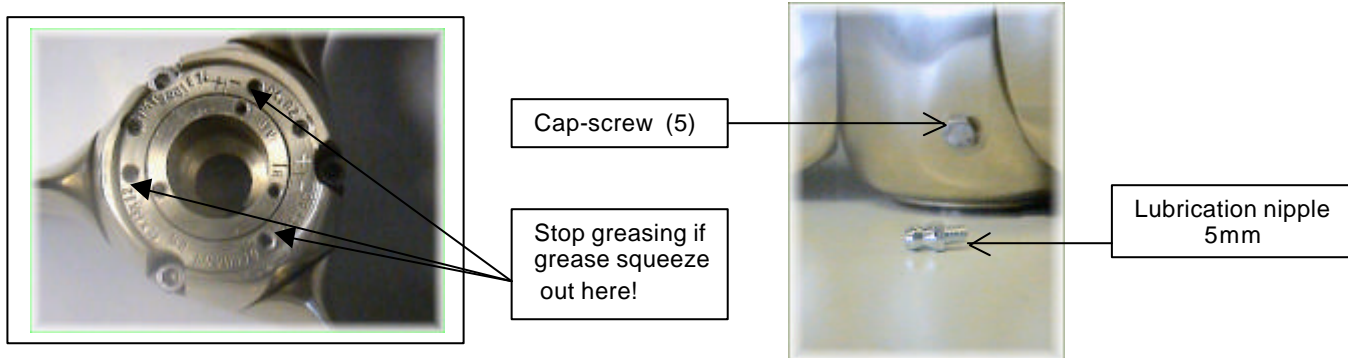

Fig.1A

Factory supplied special grease EP/SAL is recommended and available from your VARIPROP distributor.
Avoid regular white grease (sterntube-grease) !

Shock-absorber: The integrated shock-absorber reduces unpleasant operating noises. The pitch stops are substantially protected against wear. At rotating the blades by hand, you can feel the shock-absorber function. This "heavy" turning at the absorber area is normal and necessary for the function !

Make sure that you always keep the zinc anode in good condition. The Variprop must be protected by a lot of zinc, so also use a zinc anode onto the shaft if possible. Use fine sandpaper to clean the aft of the end boss and the forward face of the Variprop-anode to give the zinc good contact with the propeller.

Tools supplied with each VARIPROP (Fig.1):

- 1x small plastic bottle with Loctite low (pink)
- 1x grease nipple 5mm
- 1x allen key 2mm (DF80) or 3mm (DF107)
- 1x allen key 4mm
- 1x allen key 5mm

necessary tools for removing the prop
after 1 or 2 seasons (page 8)

1 open-end- / box spanner 8mm	1 allen key 2mm DF- 80
1 open-end- / box spanner 24mm	1 allen key 3mm DF-107
1 open-end- / box spanner 36mm	1 allen key 4mm

necessary tools for removing the prop
after years (page 9)

1 open-end- / box spanner 10mm DF -80	1 allen key 2mm DF- 80
1 open-end- / box spanner 13mm DF-107	1 allen key 3mm DF-107
1 open-end- / box spanner 24mm	1 allen key 4mm
1 open-end- / box spanner 36mm	1 allen key 5mm DF- 80
	1 allen key 6mm DF-107

Torque settings for the prop-nut

(page 2, Fig.1, part-no.4)

Standard – thread

M 14 x 2 UNC 1/2 “-13	40 Nm / 30 ft/lb
--------------------------	------------------

M 16 x 2 BSW 5 / 8 “ – 11 UNC 5 / 8 “ - 11	60 Nm / 45 ft/lb
--	------------------

M 16 x 2 Yanmar Saildrive SD 20 & SD 31	60 Nm / 45 ft/lb
---	------------------

M 20 x 2,5 BSW 3 / 4 “ – 10 UNC 3 / 4 “ - 10	125 Nm / 95 ft/lb
--	-------------------

UNC 7 / 8 “-9	160 Nm / 115 ft/lb
---------------	--------------------

M 24 x 3 BSW 1 “ - 8 UNC 1 “ - 8	210 Nm / 155 ft/lb
--	--------------------

M 27 x 3	315Nm / 230 ft/lb
----------	-------------------

M 30 x 3,5 UNC 1 1/8” - 7	350 Nm / 255 ft/lb
------------------------------	--------------------

Fine – thread

M 14 x 1,5 BSF 1/2 “ - 16	40 Nm / 30 ft/lb
------------------------------	------------------

M 16 x 1,5 BSF 5 / 8 “ – 14 UNC 5 / 8 “ - 18	70 Nm / 50 ft/lb
--	------------------

M 20 x 1,5 BSF 3 / 4 “ – 12 UNC 3 / 4 “ - 16	135 Nm / 100 ft/lb
--	--------------------

M 20 x 2 Yanmar Saildrive SD 40 & SD 50	100 Nm / 75 ft/lb
---	-------------------

M 24 x 2 BSF 1 “ - 10 UNF 1 “ - 12	225 Nm / 165 ft/lb
--	--------------------

M 30 x 2	430 Nm / 315 ft/lb
----------	--------------------

SUBJECT TO TECHNICAL ALTERATIONS; ERRORS and MISPRINTS